



AeroTow T2

User manual



A better way to tug.
Plane and Simple.

Specs



Tires
16" x 6.50



Pulling capacity
15,000 lbs. on
level ground



T2 Weight
500 lbs.



Drive
1800 watt
2 mph. max



Controls
Electric
Forward/reverse
Speed
Light



Battery & Charger
24V (x2 12V), AGM
batteries
15 amp charger

Precautions

- The operator is responsible for safe tug operation and for any aircraft or hangar damage resulting from operational errors.
- Familiarize yourself with the tug's throttle and speed response before attaching an aircraft. The tug does not stop immediately; this is intentional to help protect the aircraft.
- Aircraft should never be moved on any type of uneven, sloping, or hilly terrain.
- Store your tug in a dry location when not in use.
- Always turn the tug off while not in use. The tug will automatically turn off after 25 minutes. Toggle the power switch to turn on.
- Leave your tug plugged in while not in use. The smart charge feature will prevent damage to the battery.
- Extreme cold can negatively impact the batteries, but climate control is not necessary in most circumstances.
- Recommended tire pressure is approximately 28 PSI. Always reference the tire sidewall for the exact pressure.

Labeling

Always follow all warnings and labeling on the T2.



&



How-To Video

Scan the QR code or visit amigoaerotow.com/owners/ to watch a video on how to use your T2.

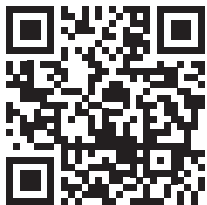

Charging Information

To maximize range and battery life, keep the battery charged during periods of non-use and ensure it is fully charged before operation. The charger includes built-in overcharge protection and is preprogrammed to optimize charging for the batteries.

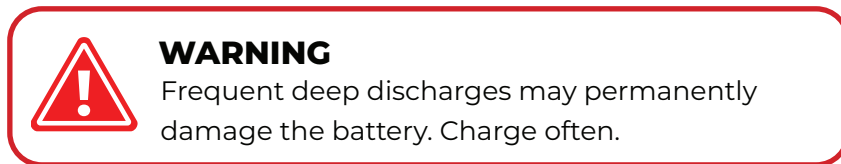

The enclosure displays a battery gauge with 5 bars to show the current charge levels.



<10% remaining battery



50% remaining battery



+90% remaining battery

At the start of the charge cycle, the bars on the battery gauge will blink for 45 seconds and then stay lit. The bars will light up incrementally until all 5 are lit, indicating the batteries are fully charged. All 5 bars will blink at the end of the charge cycle.

Assembly

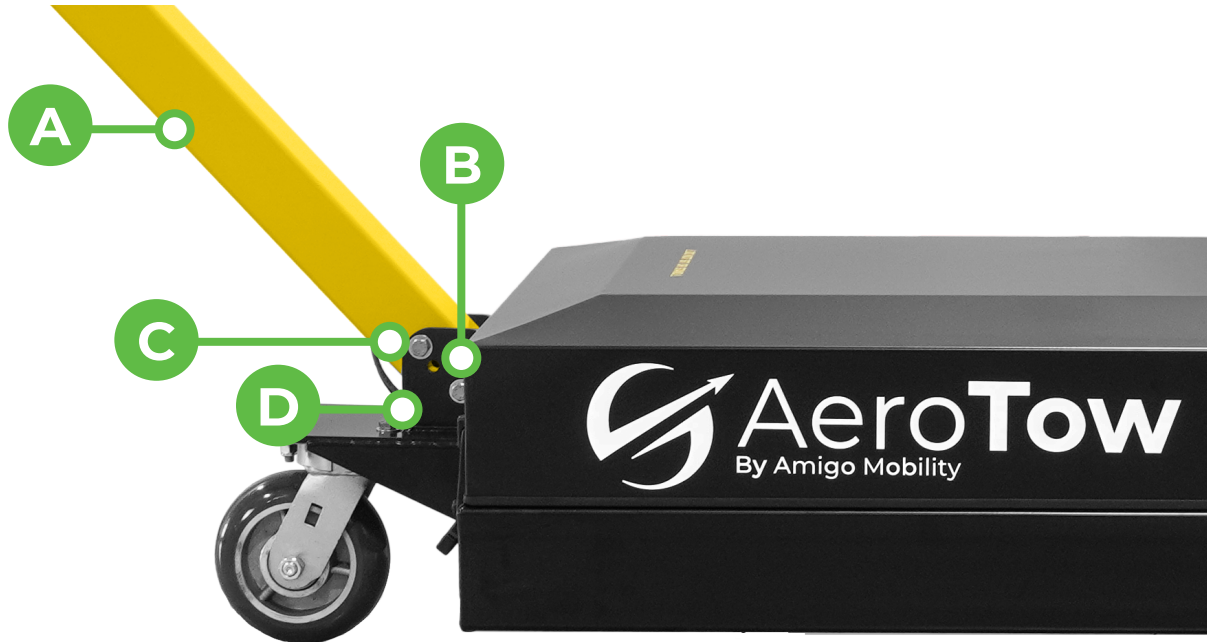

- A. Handle
- B. Frame attachment bolt
- C. Height/angle adjustment bolt
- D. Frame

1. Cut the zip ties to remove the handle (A) from the T2 frame. Remove the bolts and nuts.
2. Insert the handle (A) into the frame (D). Insert the high/angle adjustment bolt (C) and leave the nut loose.
3. Lift the handle up and down to locate the two positions where the frame attachment bolt (B) can be inserted. Then install it in the position that provides your preferred angle or height.
4. Tighten both bolts securely.
5. Connect the enclosure wire (E) to the connector (F) on the wire harness (Figure 1).
6. Connect the safety switch cable (H) to the connector (G) on the wire harness (Figure 1).

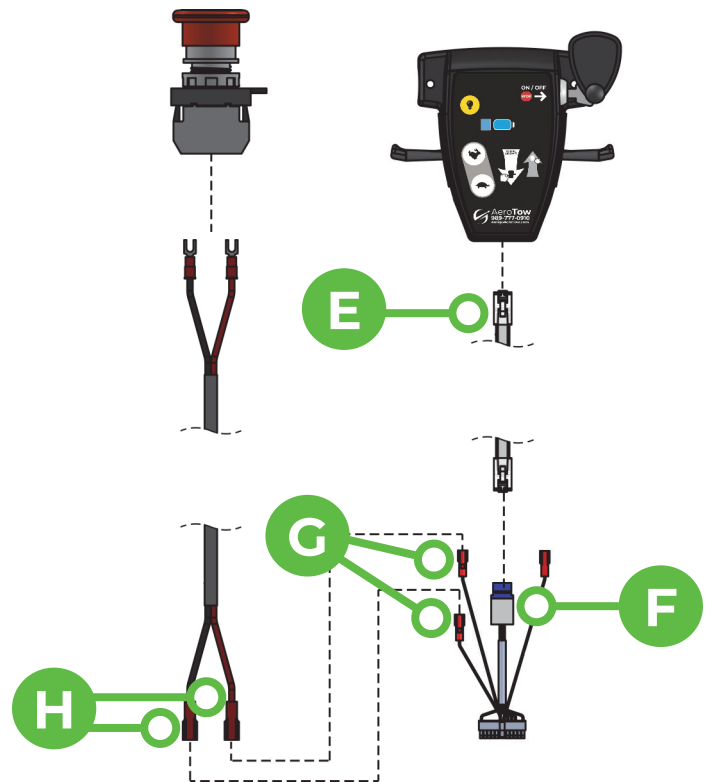
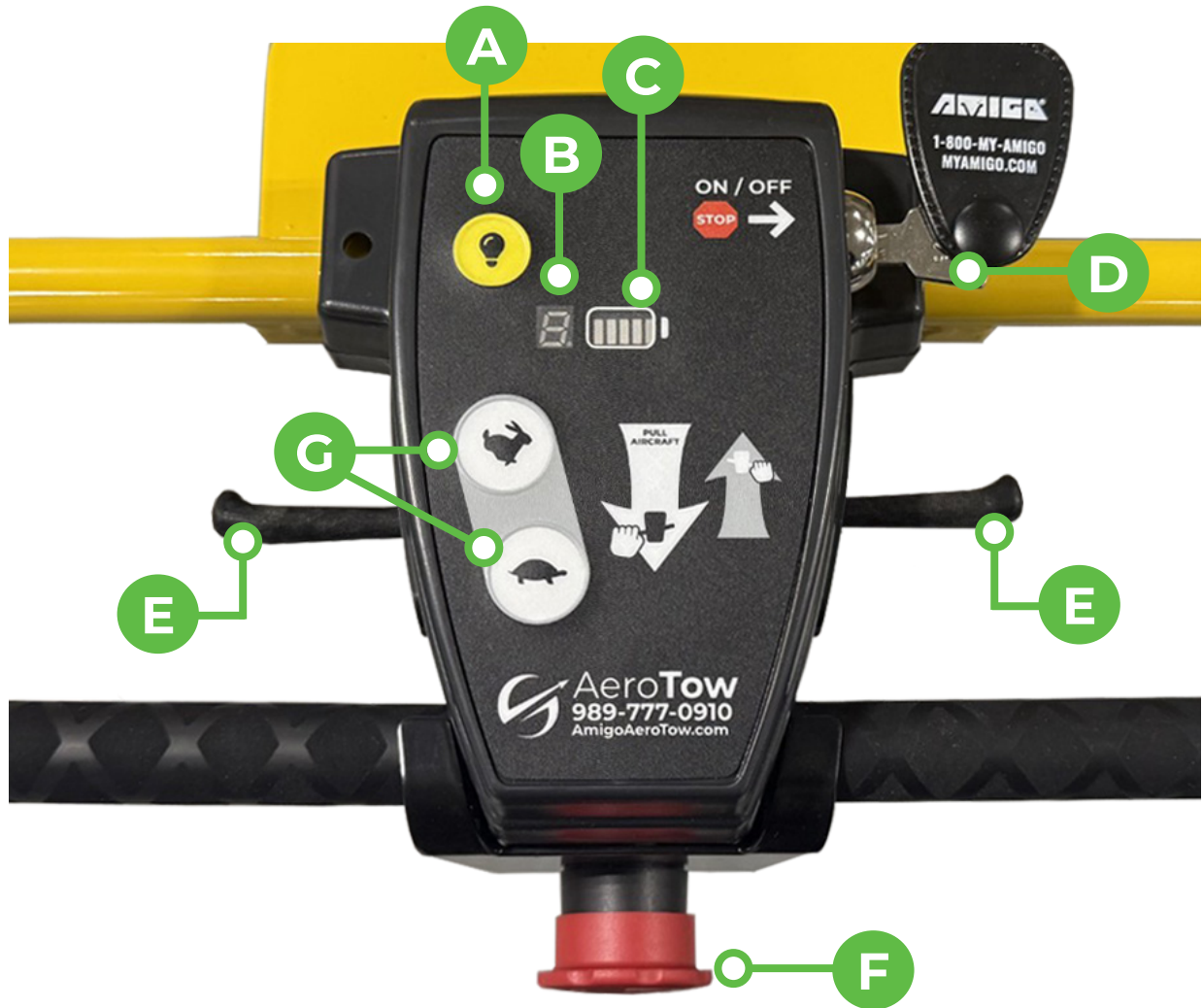

Figure 1

See Page 8 for wiring diagram

| Handle Controls



A. Toggles light on/off

B. Speed indicator/Troubleshooting

Note: Speed does not indicate miles per hour. If the number is flashing, see Page 7 for diagnostic information.

C. Battery gauge

D. T2 key on/off

E. Throttle levers. To move forward pull the right throttle lever toward you. To operate in reverse, pull the left throttle lever toward you. Releasing the throttle lever will cause the T2 to roll to a stop.

F. Emergency stop

Note: To reset the belly switch, turn the handle clockwise until it pops out. There are arrows on the front that show the direction to turn it.

G. Faster (rabbit)/Slower (turtle)

Connecting Your Aircraft

1. To connect the tug to the aircraft, first **chock the aircraft tires**.
2. Position the T2 so the plane's nose wheel is in the center of the ramp.
3. Loosen the winch strap using the winch controller (Figure 2) by pressing the left button, and wrap the axle strap around the front landing gear.
4. After securely attaching the axle strap back onto the winch strap, remove the chocks from all the wheels on the nose (front) side of the aircraft. This will allow the plane to roll forward freely and prevent it from rolling backward.
5. Press the right button to pull the plane up the ramp until the wheel hits the stop plate.
6. Remove the remaining chocks and tow the aircraft.



Figure 2

Moving Your Aircraft

1. Check the surrounding area and remove any obstacles or obstructions before moving your aircraft. **Then remove the chocks.**
2. To move forward, pull the right throttle lever toward you. To reverse, pull the left throttle lever toward you. Release the throttle lever to gradually roll to a stop. The T2 has four speed levels. Press the rabbit or turtle button twice quickly to change one level. Repeat after a short pause to continue changing speeds.

Disconnecting Your Aircraft

1. **Chock your aircraft.**
2. Loosen the winch strap and remove the wheel strap.
3. Slowly move your tug away from the aircraft using the reverse switch.



CAUTION

Always chock the aircraft wheels when parked, not in use, or when attaching your tug.

Diagnostic Codes

If the tug requires service, the speed indicator may **flash** one of the following numbers. Use this guide to help diagnose the issue. For further support, contact the Amigo customer service department at 800-248-9131.



Note: The first solution listed for each diagnostic code has been shown to fix the problem 80% of the time. Attempt solutions in the order listed.

1

Problem:
Brake circuit is shorted.

Solution:

- (1) Check all connections running from the brake to the controller.
- (2) Disconnect the brake wires from the controller. Restart the Amigo. If the code changes to a 2, replace the brake.
- (3) Replace the controller.

2

Problem:
Brake circuit is open.

Solution:

- (1) Check all connections running from the brake to the controller.
- (2) Replace the brake.
- (3) Replace the controller.

3

Problem:
Motor circuit is shorted.

Solution:

- (1) Check all connections running from the motor to the controller.
- (2) Disconnect the motor wires from the controller. Restart the Amigo. If the code changes to a 4, replace the motor.
- (3) Replace the motor controller.

4

Problem:
Motor circuit is open.

Solution:

- (1) Check all connections running from the motor to the controller.
- (2) Replace the motor.
- (3) Replace the controller.

5

Problem:
Throttle circuit out of range.

Solution:

- (1) Check the handle cable, the receptacle on the controller and the throttle enclosure are in good condition.
- (2) Check to make sure the throttle levers move freely and returns to neutral position.
- (3) Replace the throttle device.

6

Problem:
Motor controller over temperature

Solution:

- (1) Turn the Amigo off and sit idle for 15 minutes. Restart and drive for 5 minutes to see if the code disappears.
- (2) Replace the brake and motor if causing excessive amp draw.
- (3) Replace the controller.

7

Problem:
Battery charger did not change to float mode during battery charging. **Note:** This code will only appear while the tug is plugged in.

Solution:

- (1) Replace the DC Charge Cable and check by allowing the charger to run through a full charge cycle.
- (2) Replace the battery charger and check by allowing the charger to run through a full charge cycle.
- (3) Replace the controller and check by allowing the charger to run through a full charge cycle.

You must allow the battery charger to run through a full charge cycle to make sure the problem has been corrected.

8

Problem:
Motor controller fault condition.

Solution:

- (1) Turn the Amigo off and sit idle for 1 minute. With a voltage meter connected to the batteries, restart the Amigo and measure the battery voltage, if it drops more than 1-volt then replace the batteries.
- (2) Replace the controller.

Wiring Diagram

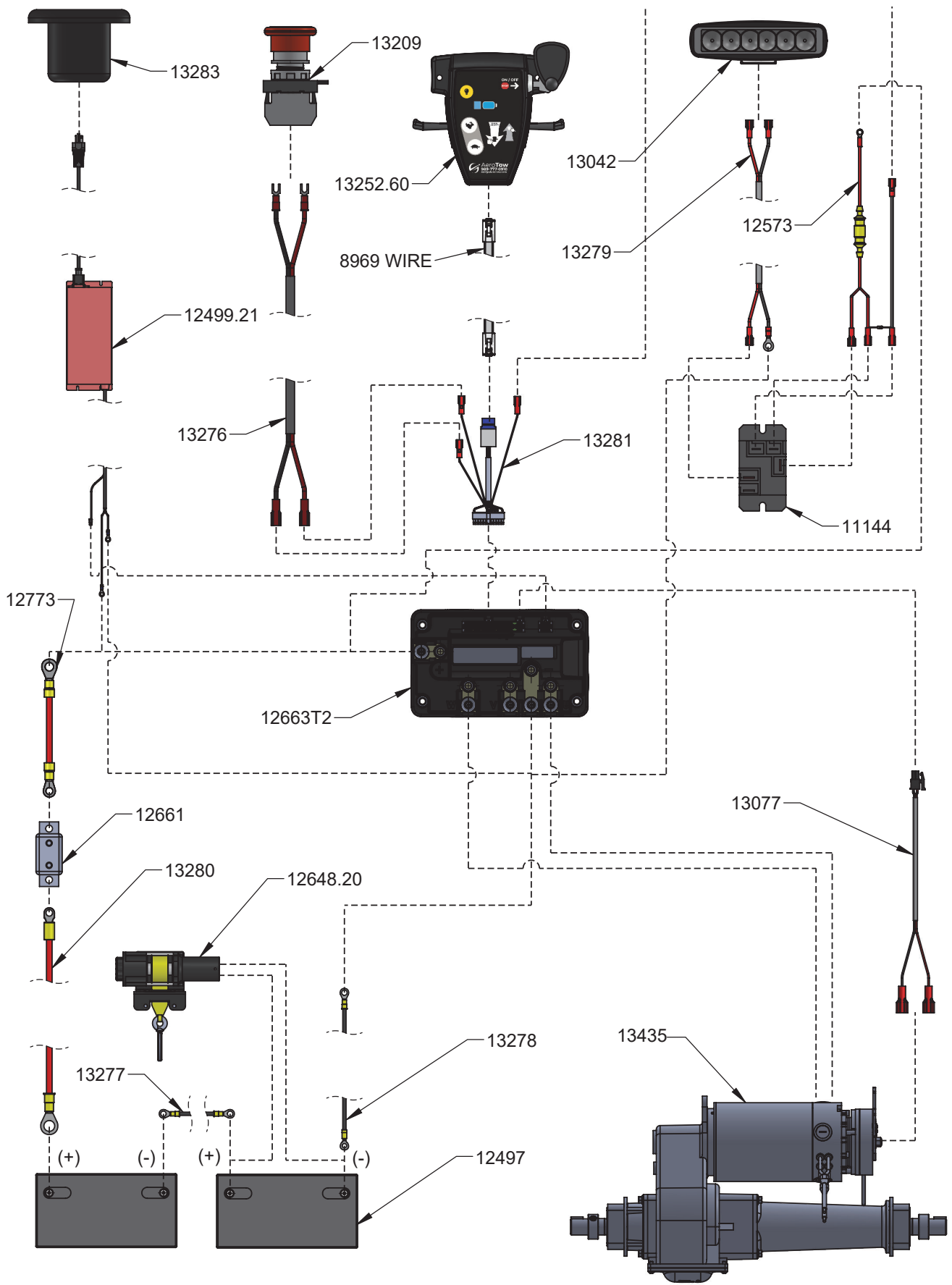

Exploded View

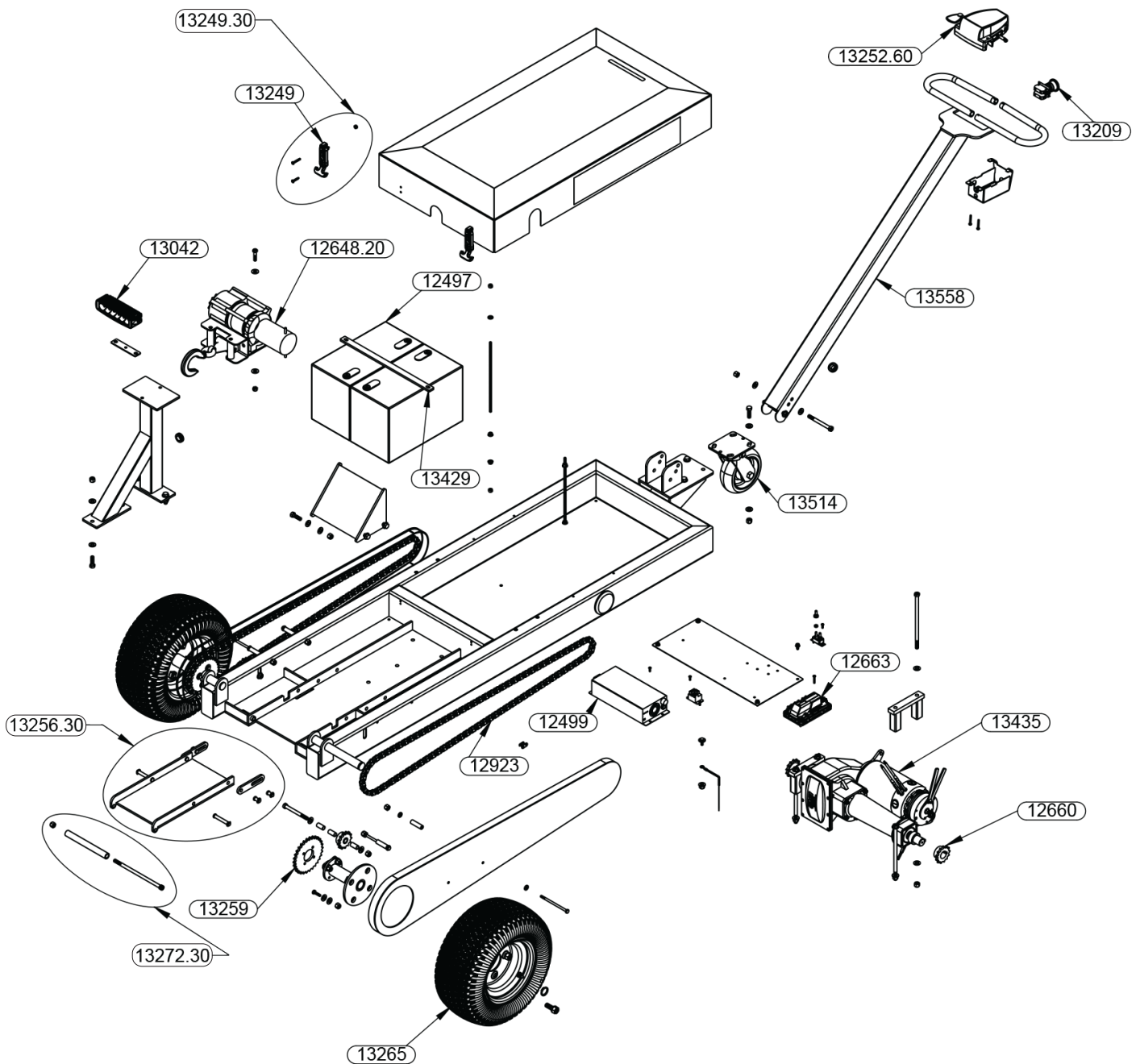

Note: Wires are not shown on the exploded view. Most wires and cables will have a sticker wrapped around them with the part number.

Parts List

Part No.	Description	QTY.
12497	Battery 12V 105Ah 120WH AGM	2
12499	Charger 24V AGM 15A	1
1648.20	Winch lift AeroTow w/strap hook	1
12660	Gear 13T #40	2
12663T2	Controller AeroTow T2	1
12923	Chain drive T2	2
13042	Light LED 6" flood	1
13209	Switch 22mm mush. red maintained	1
13249	Latch weather resistant	4
13252.60	Enclosure Hi/Lo 1-4 key AeroTow	1
13259	Sprocket 30 tooth	2
13265	Wheel 16x650-8	2
13429	Bracket battery retention	1
13435	Drive 24V T-2	1
13514	Wheel 06" caster MHL w/o brake	1
13558	Handle T2	1

Warranty Coverage

General Warranty Provisions

Amigo Mobility International, Inc. (AMI) disclaims any responsibility for personal injury or property damage resulting from the improper or unsafe use of its products. AMI warrants its products to the original purchaser and commences on the date of shipment.

The warranties do not cover the failure of any part or accessory due to:

- Shipping damage.
- Abuse, misuse, accidental damage, or acts of nature.
- Exceeding the specified weight capacity of the model.
- Modifying the product, or installing accessories not authorized by AMI.

Warranty Coverage

AMI will repair or replace a part that is defective in material or workmanship under normal use. AMI may use factory refurbished parts rather than new parts for some warranty repairs.

Warranty replacement parts are covered for the remainder of the original AMI unit warranty.

- Electronic components have a two-year warranty.
- Batteries supplied by AMI have a six-month warranty.
- Damage caused by lack of charging, battery moisture, spillage, or leakage is exclusive of warranty.
- Batteries must be charged consistently; you can leave them plugged into the charger provided when not in use.
- AMI provides an ARS tag with warranty parts that are required to be returned to the factory (continental United States only).
- If inspection determines that a returned part is inoperable due to a non-warranty nature, credit for replacement parts ordered will not be issued.

This warranty supersedes and is in lieu of all other warranties expressed or implied, and no person, agent, or dealer is authorized to give any warranties on behalf of AMI, nor to assume for AMI any other liability concerning any of its products unless made in writing and signed by an official of AMI.

This warranty gives you specific rights, with the possibility of other rights, which vary depending upon your locality.

Customer Satisfaction

Your complete satisfaction is our main goal. Please contact us at 800-248-9131 or service@myamigo.com if you have questions regarding service.

To register your tug, please scan the QR code or visit amigoaerotow.com/owners/warranty.





AMIGO AEROTOW

989-777-0910 | amigoaerotow.com

© 2026 Amigo Mobility International, Inc. AeroTow® is a registered trademark of Amigo Mobility International, Inc.
0426 - 13359 Rev B